

SUPER FAST DIODE MODULE TYPE 400A / 600V

Features

High Surge Capability
Type 600V V_{RRM}

Maximum Ratings

Junction Operating Temperature : -55 °C to+175 °C
Storage Temperature : -55 °C to+175 °C

Part Number	Maximum Recurrent Peak Reverse Voltage	Maximum RMS Voltage	Maximum DC Blocking Voltage
MUR400A60CT(R)	600V	420V	600V

Electrical Characteristics @ 25 °C Unless Otherwise Specified

Item	Symbol	Rating	Conditions
Average Forward Current (Per pkg)	$I_{F(AV)}$	400 A	$T_C = 125^\circ\text{C}$
Peak Forward Surge Current (Per diode)	I_{FSM}	3300 A	8.3ms , half sine
Mounting Torque		35-40 In-lb 30-40 In-lb 8-10 In-lb	Terminal torque Outside holes Center hole

Item (Per diode)	Symbol	Rating		Conditions
		Typ.	Max	
Instantaneous Forward Voltage *	V_F	1.30V	1.45V	$I_{FM}=200A ; T_J = 25^\circ\text{C}$
Instantaneous Reverse Current At Rated DC Blocking Voltage	I_R		25 μA 3mA	$T_J = 25^\circ\text{C}$ $T_J = 125^\circ\text{C}$
Reverse Recovery Time	T_{rr}		200ns	$I_F=0.5A, I_R=1.0A,$ $I_{RR}=0.25A$
Reverse Recovery Time	T_{rr}	45ns 85ns		$T_J = 25^\circ\text{C}$ $T_J = 150^\circ\text{C}$
Peak Recovery Current	I_{rrm}	4A 12A		$T_J = 25^\circ\text{C}$ $T_J = 150^\circ\text{C}$
Reverse Recovery Charge	Q_{rr}	170nC 600nC		$T_J = 25^\circ\text{C}$ $T_J = 150^\circ\text{C}$
Thermal Resistance Junction To Case	$R_{\theta JC}$		0.35 °C/W	

*Pulse Test: Pulse Width 300 μsec , Duty Cycle < 2%

TWIN TOWER

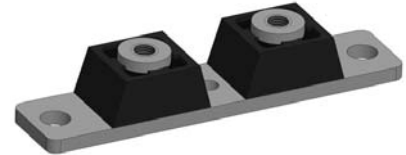

Dimensions in mm (1 mm = 0.0394")

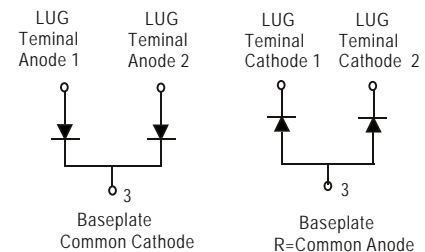
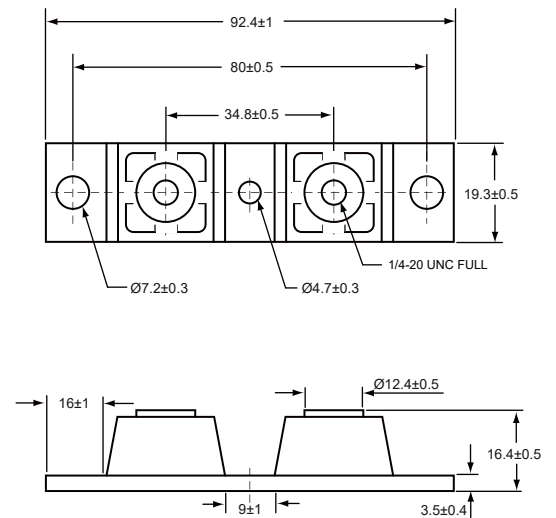

Figure .1- Typical Forward Characteristics

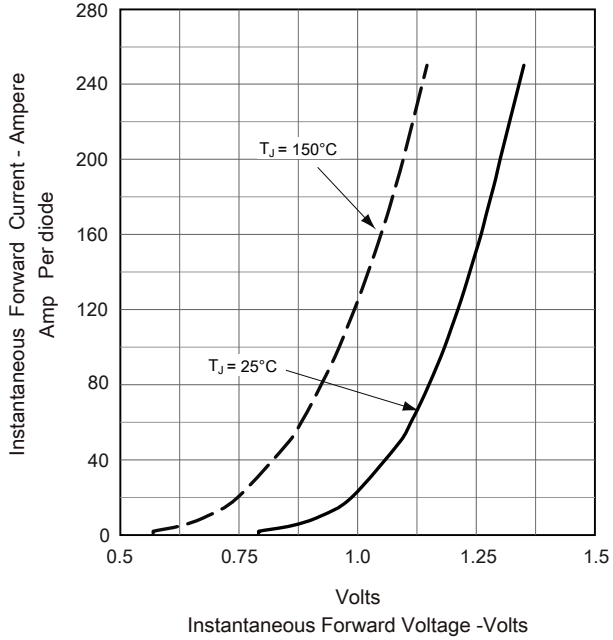

Figure .2-Forward Derating Curve

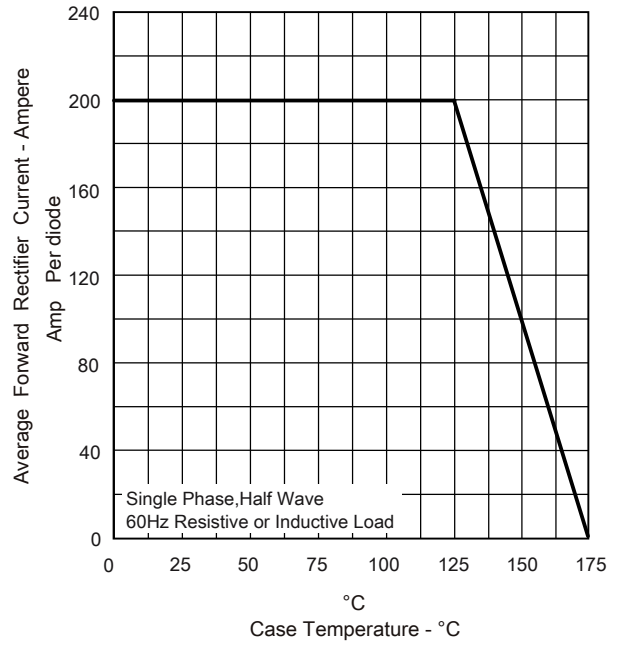

Figure .3-Peak Forward Surge Current

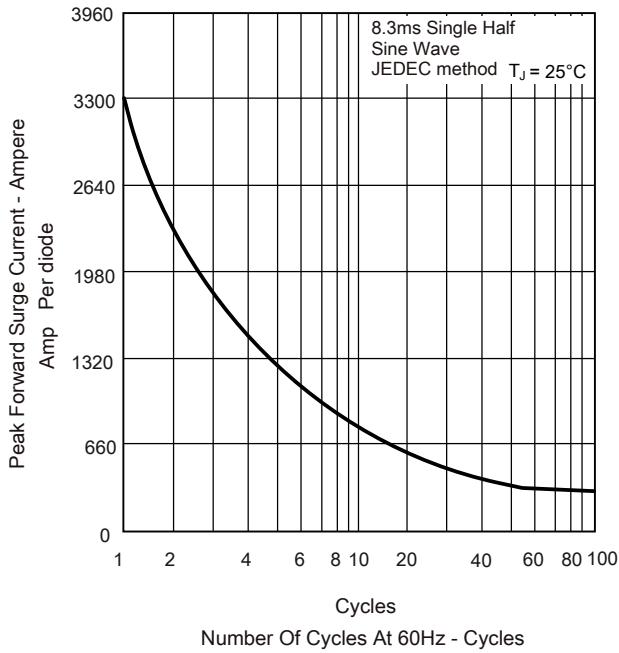
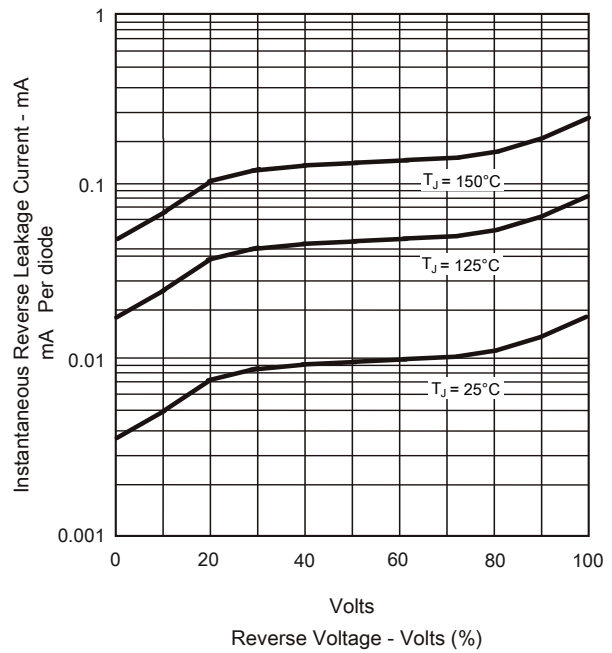

Figure .4-Typical Reverse Characteristics



Disclaimer

DACO Semiconductor reserves the right to make modifications, enhancements, improvements, corrections, or other changes to this document and any product described herein without prior notice. For the most up-to-date version, please visit our website.

DACO Semiconductor makes no warranty, representation, or guarantee regarding the suitability of its products for any particular purpose, nor does DACO Semiconductor assume any liability arising out of the application or use of any product or circuit, and specifically disclaims any liability, including without limitation special, consequential or incidental damages.

Purchasers are responsible for its products and applications using DACO Semiconductor products, including compliance with all laws, regulations, and safety requirements or standards, regardless of any support or application information provided by DACO Semiconductor. "Typical" parameters that may be provided in DACO Semiconductor datasheets and/or specifications can and do vary in different applications and actual performance may vary over time. All operating parameters, including "Typical" must be validated for each customer application by the customer's technical experts.

DACO Semiconductor products are not designed, authorized, or warranted to be suitable for use in life support, life-critical or safety-critical systems, or equipment, nor in applications where failure or malfunction of DACO Semiconductor's product can reasonably be expected to result in personal injury, death or severe property or environmental damage. DACO Semiconductor accepts no liability for the inclusion and/or use of DACO Semiconductor's products in such equipment or applications and therefore such inclusion and/or use is at the customer's own risk.

Purchasers who buy or use DACO Semiconductor products for any unintended or unauthorized applications are required to indemnify and absolve DACO Semiconductor, its suppliers, and distributors from any claims, costs, damages, expenses, and reasonable attorney fees arising out of, directly or indirectly, any claim of personal injury or death associated with such unintended or unauthorized use, even if such claim alleges that DACO Semiconductor was negligent regarding the design or manufacture of the part.

No part of this publication may be reproduced or transmitted in any form or by any means, electronic or mechanical, including photocopying and recording, or by any information storage and retrieval system, or otherwise, without the prior written permission of DACO Semiconductor Co., Ltd.