

IGBT Power Module

1200V / 300A

Preliminary

Features

- ◆ Fast Switching Trench / Field Stop IGBT Technology
- ◆ Low Switching Losses
- ◆ Super Fast Diodes
- ◆ High Short Circuit Capability

Applications

- ◆ Welder / Power Supply
- ◆ UPS / Inverter
- ◆ Industrial Motor Drive

HDA-15262



Circuit Diagram Headline

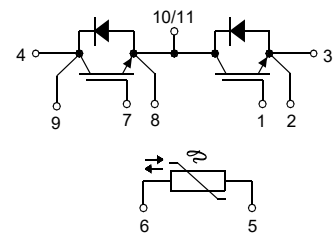

Maximum Ratings (T_C=25°C)

Item	Symbol	Rated Value	Unit
Collector-Emitter Voltage	T _{VJ} = 25°C V _{CES}	1200	V
Gate-Emitter Peak Voltage	V _{GES}	±20	V
Continuous DC Collector Current	T _C = 100°C T _C = 25°C I _{C,nom.} I _C	300 450	A
Repetitive Peak Collector Current	t _p = 1ms I _{CRM}	600	A
Total Power Dissipation	P _{tot}	1330	W
Isolation Voltage	RMS, f=50Hz, t=1min V _{iso}	2500	V
Continuous DC Forward Current	I _F	300	A
Repetitive Peak Forward Current	t _p = 1ms I _{FRM}	600	A
Temperature under switching conditions	T _{VJ op}	-40~+150	°C
Storage Temperature	T _{stg}	-40~+125	°C
Mounting Torque	Module Base to Heatsink (M5)	3~6	N.m
	Busbar to Terminal (M6)	3~6	

Package Outlines

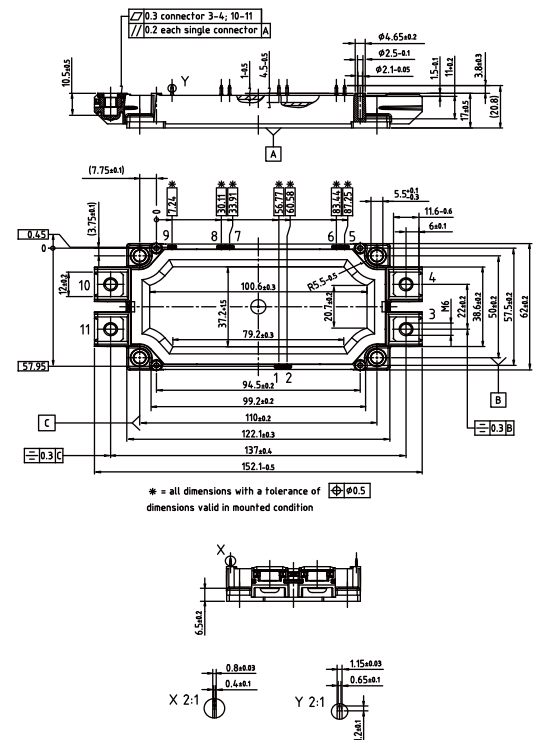

Dimensions in mm (1 mm = 0.0394")

■ Electrical Characteristics ($T_{vj} = 25^{\circ}\text{C}$)

Characteristics	Symbol	Test Conditions	Min.	Typ.	Max.	Unit
Collector-emitter saturation voltage	$V_{CE\text{ sat}}$	$I_C = 300\text{A}, V_{GE} = 15\text{V}$ $T_{vj} = 25^{\circ}\text{C}$ $I_C = 300\text{A}, V_{GE} = 15\text{V}$ $T_{vj} = 125^{\circ}\text{C}$		1.75 2.0	2.1	V
Gate threshold voltage	$V_{GE\text{ th}}$	$I_C = 11.5\text{mA}, V_{CE} = V_{GE}, T_{vj} = 25^{\circ}\text{C}$	5.5	6	6.6	V
Gate charge	Q_G	$I_C = 300\text{A}, V_{CE} = 600\text{V}, V_{GE} = 15\text{V}$		874		nC
Internal gate resistor	$R_{G\text{ int}}$	$T_{vj} = 25^{\circ}\text{C}$		1.91		Ω
Input capacitance	C_{ies}	$f = 100\text{KHz}, T_{vj} = 25^{\circ}\text{C}, V_{CE} = 25\text{V}, V_{GE} = 0\text{V}$		28		nF
Output capacitance	C_{oes}	$f = 100\text{KHz}, T_{vj} = 25^{\circ}\text{C}, V_{CE} = 25\text{V}, V_{GE} = 0\text{V}$		1.3		nF
Reverse transfer capacitance	C_{res}	$f = 100\text{KHz}, T_{vj} = 25^{\circ}\text{C}, V_{CE} = 25\text{V}, V_{GE} = 0\text{V}$		0.26		nF
Collector-emitter cut-off current	I_{CES}	$V_{CE} = 1200\text{V}, V_{GE} = 0\text{V}, T_{vj} = 25^{\circ}\text{C}$			1	mA
Gate-emitter leakage current	I_{GES}	$V_{CE} = 0\text{V}, V_{GE} = 20\text{V}, T_{vj} = 25^{\circ}\text{C}$			100	nA
Turn-on delay time, inductive load	$t_{d\text{ on}}$	$I_C = 300\text{A}, V_{CE} = 600\text{V}$ $T_{vj} = 25^{\circ}\text{C}$		246		ns
		$V_{GE} = \pm 15\text{V}$ $T_{vj} = 125^{\circ}\text{C}$		254		
		$R_{G(\text{on})} = 0.5\Omega, R_{G(\text{off})} = 0.5\Omega$ $T_{vj} = 150^{\circ}\text{C}$		243		
Rise time, inductive load	t_r	$I_C = 300\text{A}, V_{CE} = 600\text{V}$ $T_{vj} = 25^{\circ}\text{C}$		46		ns
		$V_{GE} = \pm 15\text{V}$ $T_{vj} = 125^{\circ}\text{C}$		56		
		$R_{G(\text{on})} = 0.5\Omega, R_{G(\text{off})} = 0.5\Omega$ $T_{vj} = 150^{\circ}\text{C}$		73		
Turn-off delay time, inductive load	$t_{d\text{ off}}$	$I_C = 300\text{A}, V_{CE} = 600\text{V}$ $T_{vj} = 25^{\circ}\text{C}$		324		ns
		$V_{GE} = \pm 15\text{V}$ $T_{vj} = 125^{\circ}\text{C}$		362		
		$R_{G(\text{on})} = 0.5\Omega, R_{G(\text{off})} = 0.5\Omega$ $T_{vj} = 150^{\circ}\text{C}$		370		
Fall time, inductive load	t_f	$I_C = 300\text{A}, V_{CE} = 600\text{V}$ $T_{vj} = 25^{\circ}\text{C}$		42		ns
		$V_{GE} = \pm 15\text{V}$ $T_{vj} = 125^{\circ}\text{C}$		63		
		$R_{G(\text{on})} = 0.5\Omega, R_{G(\text{off})} = 0.5\Omega$ $T_{vj} = 150^{\circ}\text{C}$		72		
Turn-on energy loss per pulse	E_{on}	$I_C = 300\text{A}, V_{CE} = 600\text{V}$ $T_{vj} = 25^{\circ}\text{C}$		8.8		mJ
		$V_{GE} = \pm 15\text{V}, (T_{vj} = 150^{\circ}\text{C})$ $T_{vj} = 125^{\circ}\text{C}$		18		
		$R_{G(\text{on})} = 0.5\Omega, R_{G(\text{off})} = 0.5\Omega$ $T_{vj} = 150^{\circ}\text{C}$		24		
Turn-off energy loss per pulse	E_{off}	$I_C = 300\text{A}, V_{CE} = 600\text{V}$ $T_{vj} = 25^{\circ}\text{C}$		21		mJ
		$V_{GE} = \pm 15\text{V}, (T_{vj} = 150^{\circ}\text{C})$ $T_{vj} = 125^{\circ}\text{C}$		26		
		$R_{G(\text{on})} = 0.5\Omega, R_{G(\text{off})} = 0.5\Omega$ $T_{vj} = 150^{\circ}\text{C}$		28		
SC data	I_{SC}	$V_{GE} \leq 15\text{V}, V_{CC} = 800\text{V}$ $V_{CE\text{ max}} = V_{CES} - L_{sCE} \cdot di/dt$ $t_p \leq 10\mu\text{s}, T_{vj} = 150^{\circ}\text{C}$		1200		A
Thermal resistance, junction to case	R_{thJC}	per IGBT			0.094	$^{\circ}\text{C/W}$
Thermal resistance, case to heatsink	R_{thCH}	per IGBT		0.03		$^{\circ}\text{C/W}$
External gate resistance	$R_{G\text{ ext}}$	$T_{vj} = 25^{\circ}\text{C}$	0.5			Ω

■ Diode Ratings & Characteristics

Characteristics	Symbol	Test Conditions	Value	Unit
Repetitive peak reverse voltage	V_{RRM}	$T_{vj} = 25^{\circ}\text{C}$	1200	V
Continuous DC forward current	I_F		300	A
Repetitive peak forward current	I_{FRM}	$t_p = 1\text{ms}$	600	A
I^2t - value	I^2t	$V_R = 0\text{V}, t_p = 10\text{ms}, T_{vj} = 125^{\circ}\text{C}$	19000	A ² s
		$V_R = 0\text{V}, t_p = 10\text{ms}, T_{vj} = 150^{\circ}\text{C}$	15500	

Characteristics	Symbol	Test Conditions	Min.	Typ.	Max.	Unit
Forward voltage	V_F	$I_F = 300\text{A}, V_{GE} = 0\text{V}$ $T_{vj} = 25^{\circ}\text{C}$		2.2	2.4	V
		$I_F = 300\text{A}, V_{GE} = 0\text{V}$ $T_{vj} = 125^{\circ}\text{C}$		2		
Peak reverse recovery current	I_{RRM}	$I_F = 300\text{A}, -di_F/dt = 3600\text{A}/\mu\text{s}$ $T_{vj} = 25^{\circ}\text{C}$		176		A
		$V_R = 600\text{V}$ $T_{vj} = 125^{\circ}\text{C}$		304		
Recovered charge	Q_{rr}	$I_F = 300\text{A}, -di_F/dt = 3600\text{A}/\mu\text{s}$ $T_{vj} = 25^{\circ}\text{C}$		12250		nC
		$V_R = 600\text{V}$ $T_{vj} = 125^{\circ}\text{C}$		34540		
Reverse recovery energy	E_{rec}	$I_F = 300\text{A}, -di_F/dt = 3600\text{A}/\mu\text{s}$ $T_{vj} = 25^{\circ}\text{C}$		6393		uJ
		$V_R = 600\text{V}$ $T_{vj} = 125^{\circ}\text{C}$		14940		
Reverse Recovery Time	T_{rr}	$I_F = 300\text{A}, -di_F/dt = 3600\text{A}/\mu\text{s}$ $T_{vj} = 25^{\circ}\text{C}$		103		ns
		$V_R = 600\text{V}, V_{GE} = \pm 15\text{V}, T_{vj} = 150^{\circ}\text{C}$				
Thermal resistance, junction to case	R_{thJC}	per diode			0.15	$^{\circ}\text{C}/\text{W}$
Thermal resistance, case to heatsink	R_{thCH}	per diode		0.046		$^{\circ}\text{C}/\text{W}$
Temperature under switching conditions	$T_{vj\text{op}}$		-40		150	$^{\circ}\text{C}$

■ Package

Parameter	Symbol	Test Conditions	Value	Unit
Creepage distance	$d_{Creep\text{ nom}}$	terminal to baseplate, nom.	> 15	mm
Creepage distance	$d_{Creep\text{ min}}$	terminal to baseplate, min.	14.7	mm
Creepage distance	$d_{Creep\text{ nom}}$	terminal to terminal, nom.	> 19.3	mm
Creepage distance	$d_{Creep\text{ min}}$	terminal to terminal, min.	19.3	mm
Clearance	$d_{Clear\text{ nom}}$	terminal to baseplate, nom.	> 12.5	mm
Clearance	$d_{Clear\text{ min}}$	terminal to baseplate, min.	12.5	mm
Clearance	$d_{Clear\text{ nom}}$	terminal to terminal, nom.	> 10	mm
Clearance	$d_{Clear\text{ min}}$	terminal to terminal, min.	9.6	mm

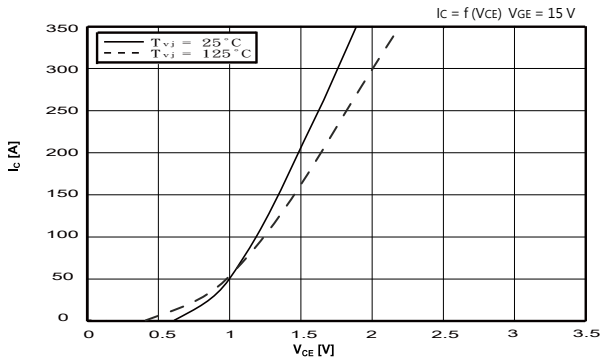
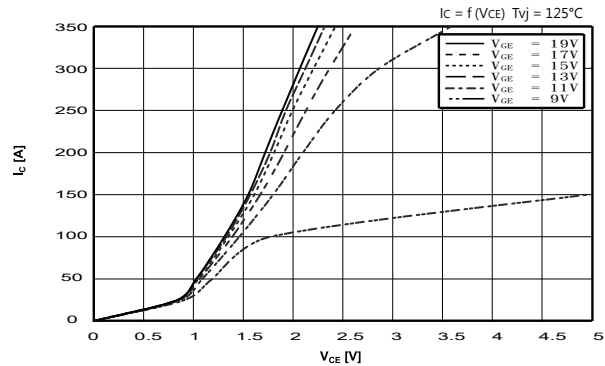
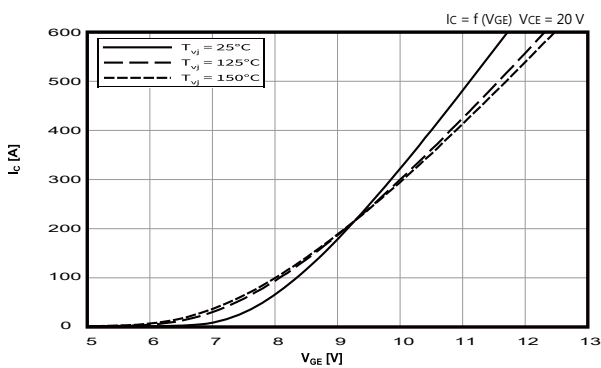
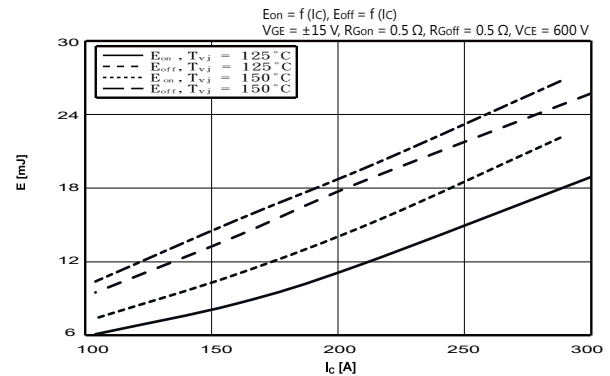
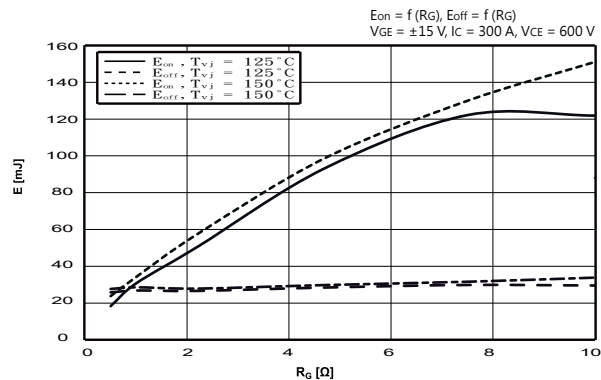
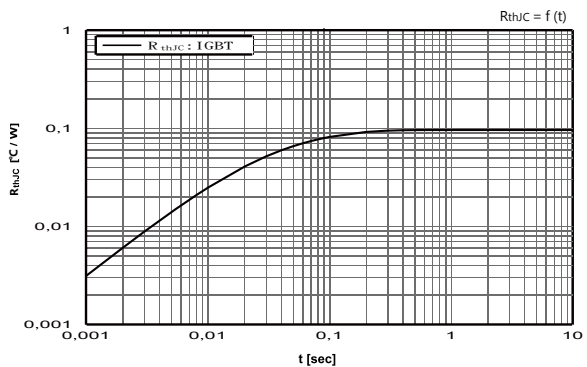
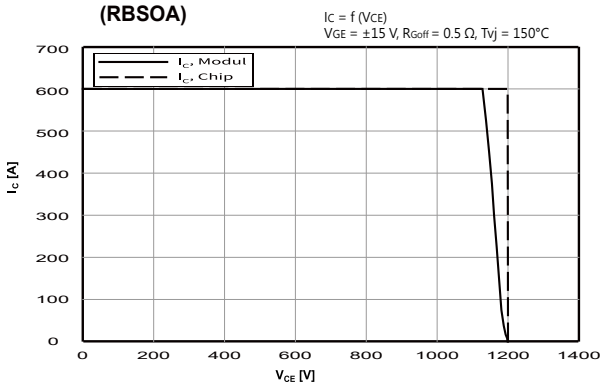
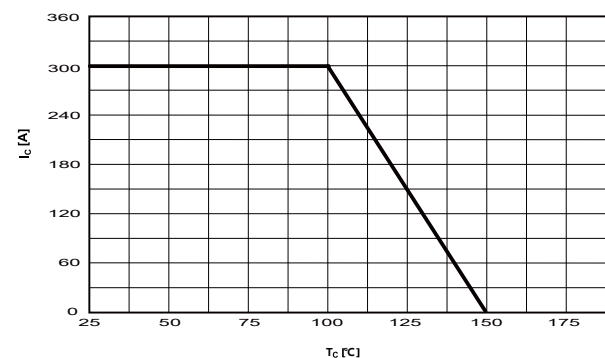
Typical Characteristics
Preliminary Data
Fig.1 Output characteristic IGBT, Inverter (typical)

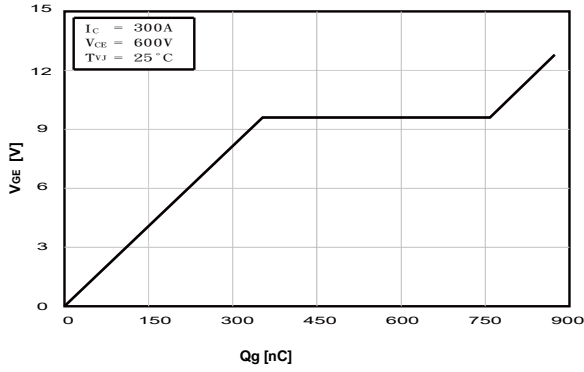
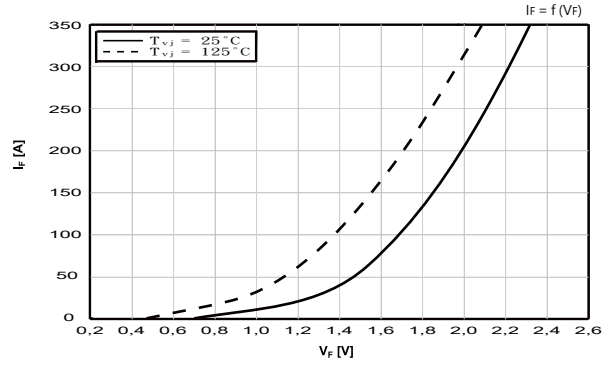
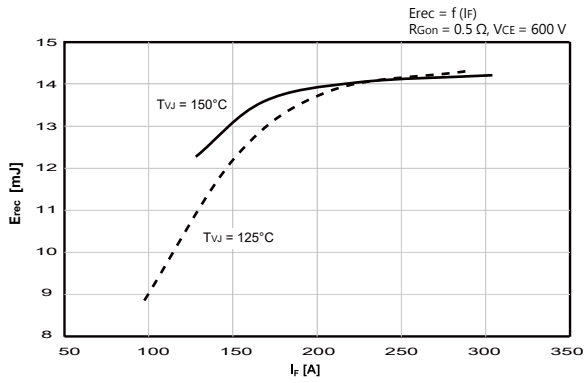
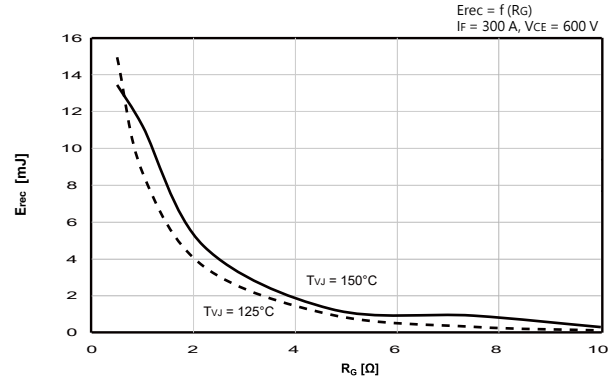
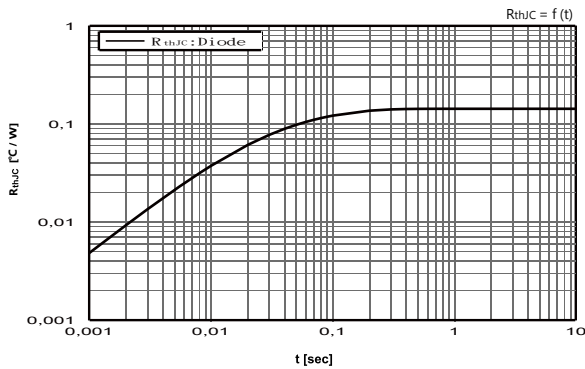
Fig.2 Output characteristic IGBT, Inverter (typical)

Fig.3 Transfer characteristic IGBT, Inverter (typical)

Fig.4 Switching losses IGBT, Inverter (typical)

Fig.5 Switching losses IGBT, Inverter (typical)

Fig.6 Transient thermal impedance IGBT, Inverter

Fig.7 Reverse bias safe operating area IGBT, Inverter (RBSOA)

Fig.8 Output characteristic IGBT, Inverter (typical)

Typical Characteristics
Preliminary Data
Fig.9 Gate Charge Characteristics(typical)

Fig.10 Forward characteristic of Diode, Inverter (typical)

Fig.11 Switching losses Diode, Inverter (typical)

Fig.12 Switching losses Diode, Inverter (typical)

Fig.13 Transient thermal impedance Diode, Inverter

Disclaimer

DACO Semiconductor reserves the right to make modifications, enhancements, improvements, corrections, or other changes to this document and any product described herein without prior notice. For the most up-to-date version, please visit our website.

DACO Semiconductor makes no warranty, representation, or guarantee regarding the suitability of its products for any particular purpose, nor does DACO Semiconductor assume any liability arising out of the application or use of any product or circuit, and specifically disclaims any liability, including without limitation special, consequential or incidental damages.

Purchasers are responsible for its products and applications using DACO Semiconductor products, including compliance with all laws, regulations, and safety requirements or standards, regardless of any support or application information provided by DACO Semiconductor. "Typical" parameters that may be provided in DACO Semiconductor datasheets and/or specifications can and do vary in different applications and actual performance may vary over time. All operating parameters, including "Typical" must be validated for each customer application by the customer's technical experts.

DACO Semiconductor products are not designed, authorized, or warranted to be suitable for use in life support, life-critical or safety-critical systems, or equipment, nor in applications where failure or malfunction of DACO Semiconductor's product can reasonably be expected to result in personal injury, death or severe property or environmental damage. DACO Semiconductor accepts no liability for the inclusion and/or use of DACO Semiconductor's products in such equipment or applications and therefore such inclusion and/or use is at the customer's own risk.

Purchasers who buy or use DACO Semiconductor products for any unintended or unauthorized applications are required to indemnify and absolve DACO Semiconductor, its suppliers, and distributors from any claims, costs, damages, expenses, and reasonable attorney fees arising out of, directly or indirectly, any claim of personal injury or death associated with such unintended or unauthorized use, even if such claim alleges that DACO Semiconductor was negligent regarding the design or manufacture of the part.

No part of this publication may be reproduced or transmitted in any form or by any means, electronic or mechanical, including photocopying and recording, or by any information storage and retrieval system, or otherwise, without the prior written permission of DACO Semiconductor Co., Ltd.